

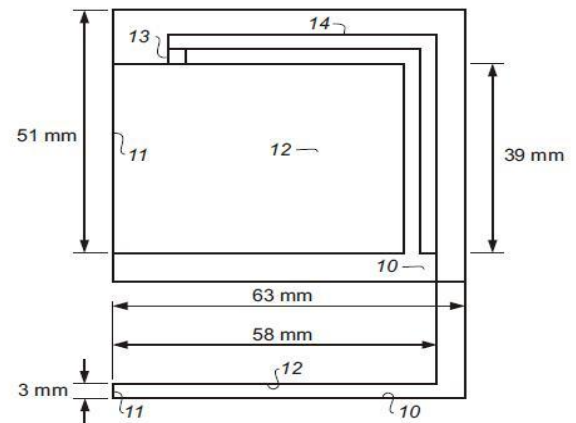

Multi-frequency antenna for RFID applications



Solution and its benefits

A multi-frequency antenna comprises main conductor plate (12); ground plane (10); short-circuit plate (11) that couples the main conductor plate to the ground plane; an open microstrip line (14) having one end attached to microcircuit and other end being open, to achieve two-frequency operation; and microchip (13) coupled to a supply site of power. The microstrip line functions as the ground terminal for the microchip.

Competitive advantage

The short circuit plate has a length corresponding to the length of the side of the main conductor plate and a rear end that necessitates no ground plane. The antenna has small size compared to conventional multiple element solutions.

Technical description

The antenna has a planar i.e. PIFA structure including a main conductor plate (12) disposed on top of a parallel ground plane (10), the main conductor plate (12) being, in addition, connected to the ground plane (10) with a perpendicular short-circuit plate (11). The short-circuit plate (11) has a length corresponding to about the length of the main conductor plate. The antenna supply point (13) is placed on the edge of the main conductor plate (12), to which it is possible to attach a microchip acting as the transceiver of an RFID transponder. The ground terminal of the microchip is arranged using an open microstrip line (14) whose end is bent towards the open edge of the main conductor plate (12) to achieve two-frequency behavior. Additional operating frequencies can be generated by using additional conductor plates.

Intellectual property rights

HIRVONEN M: MULTIFREQUENCY ANTENNA FOR RFID APPLICATIONS

- Priority date: 20050902
- WO 2007026048, FI 2005000874 A
- IPC: G06K0019-077 [I,A]; G06K0019-077 [I,C]; H01Q0001-24 [I,A]; H01Q0001-24 [I,A]; H01Q0001-24 [I,C]; H01Q0001-24 [I,C]; H01Q0001-36 [I,A]; H01Q0001-36 [I,C]; H01Q0001-38 [I,A]; H01Q0001-38 [I,C]; H01Q0005-00 [I,C]; H01Q0005-02 [I,A]; H01Q0009-04 [I,A]; H01Q0009-04 [I,C]; H04B0001-59 [I,A]; H04B0001-59 [I,C]; H04B0001-59 [I,C]

Why partner with VTT?

10 reasons for technology partnering with VTT

1. Key factor in Finland's success story with a track record to prove it
2. Licensing and co-venturing opportunities
3. Portfolio of more than 1,000 patents and inventions
4. New business and product concepts based on strong IP and world class research
5. Combined experience of more than 2,000 motivated researchers in eight focused areas of technology
6. Active member in hundreds of scientific & business communities
7. Excellent track record as coordinator and partner in EU projects
8. Collaboration with TOP 50 R&D companies in Finland
9. Global R&D partnership with 50 Fortune 500 companies
10. Market driven multi-disciplinary solutions

Additional information

VTT Technical Research Centre of Finland

Timo Joutsenoja

Business Development Manager

Tel: +358 20 722 3009

timo.joutsenoja@vtt.fi

P.O. Box 1300, FI-33101 Tampere, Finland